

SENSAPHONE®

REMOTE MONITORING SOLUTIONS

SENSAPHONE DIFFERENTIAL/STATIC PRESSURE SENSOR • FGD-0302
Installation Instructions

The Sensaphone Differential/Static Pressure sensor will allow you to monitor pressures with any Sensaphone that will accept a 4-20mA Input signal. The FGD-0302 will require a 24VDC power supply to operate (Part No: FGD-0070) for any Sensaphone that does not provide 24VDC output power.

Note on wiring: Use 22AWG shielded wiring for all connections (Sensaphone Part No. FGD-0010) and do not locate the device wires in the same conduit with wiring used to supply inductive loads such as motors. Disconnect the power supply before making any connections to prevent electrical shock or equipment damage. Make all connections in accordance with national and local codes.

Described below is the correct way to wire your sensor to your Sensaphone.

1. Follow your Sensaphone's owners manual to configure the input for a 4-20mA sensor.
2. Remove the sensor front cover.
3. Connect the 24VDC Power Supply Positive (+) to the sensor terminal marked PWR.
4. Connect the 24VDC Power Supply Negative (-) to the Sensaphone Zone Negative (-)
5. Connect the Sensaphone Zone Positive (+) to the terminal marked COM.

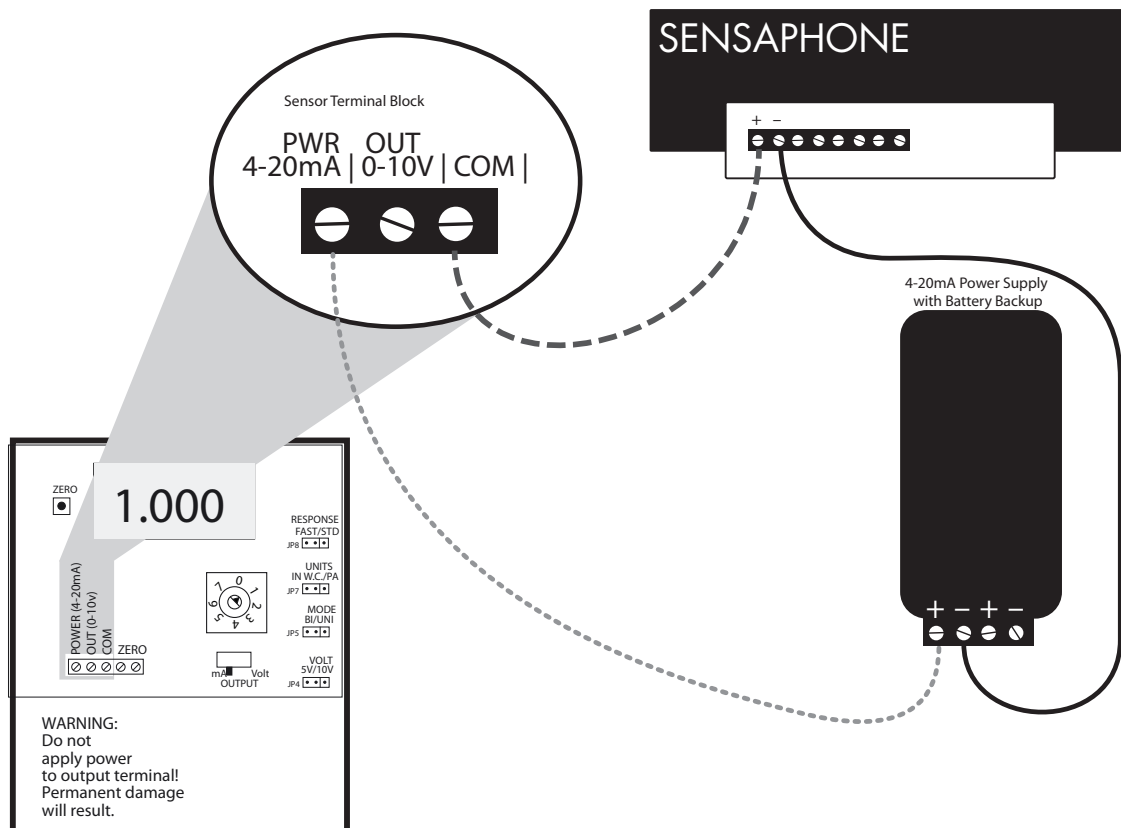

WIRING & CONFIGURATION

Connect the transmitter to the Sensaphone and power supply as indicated below.

Set the switch to current (mA) mode.

Jumper JP4: select 0-10 V.

Jumper JP5: select bidirectional or unidirectional mode.

Jumper JP7: select inches W.C. or Pascal scale

Jumper JP8: select fast or standard response time.

Align the arrow (not the slot) on the rotary switch to the desired full-scale range. LCD models momentarily indicate the selected range.

OPERATION

This device employs ceramic capacitive sensors and sophisticated temperature compensation circuitry. The sensor achieves its best accuracy after an initial warm-up period. During the first few minutes of operation, readings at zero pressure and the lowest pressure ranges appear erroneous. Following this initial warm-up period, the sensor maintains its specified accuracy and stability.

LCD DISPLAY: display momentarily indicates range "SET" when selection is made. Pressure is normally indicated on the display. Units are in inches water column (in. W.C.), Pascals (Pa) or kilopascals (kPa) as indicated on the display. The display shows OVER when the pressure is over range.

ZERO: Press and hold the ZERO pushbutton for 2 seconds or provide contact closure on 'AUX ZERO' terminal to automatically reset the output and display to zero pressure. To protect the unit from accidental zero, this feature is enabled only when the detected pressure is within about 0.1 in. W.C. (25 Pa) of factory calibration.

Range Selection Guide

Rotary Switch Position	Inches W.C.	Pascal
0	0.1	25
1	0.25	50
2	0.5	100
3	1	250
4	2.5	0.5 kPa
5	5	1 kPa
6	10	2.5 kPa
7	10	2.5 kPa

INSTALLATION

1. Plan the installation. Panel or duct mount?

Panel Installations

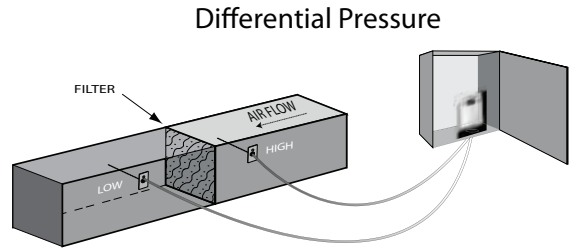
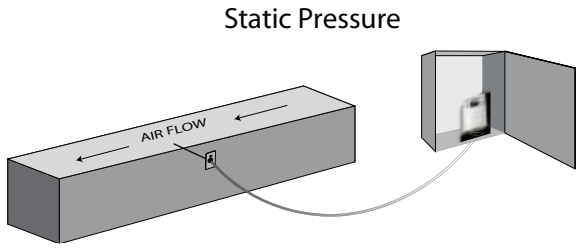

Duct Installations

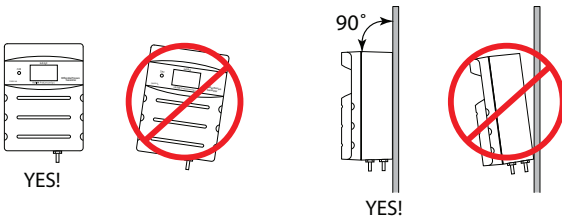
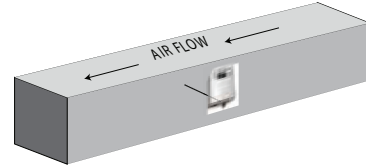
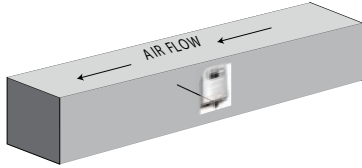

- For duct mount applications, thread the probe into the back of the device housing.
- Configure the internal tubing for the selected installation method as shown below. Use the larger diameter tubing for the duct mount configuration.

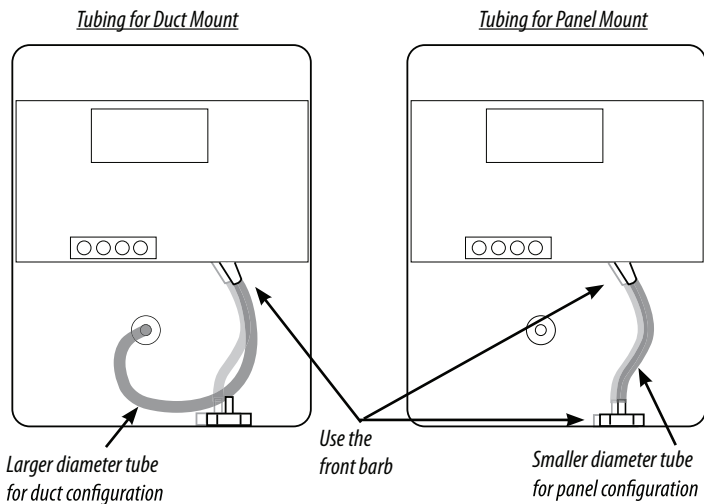

4. Mount the transducer (see the screw hole diagram). Position the transducer vertically.

Screw Hole Mounting

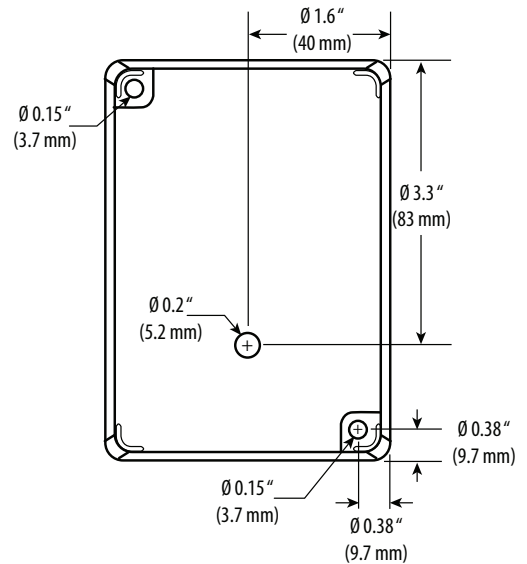

5. Determine the length of pilot tubing needed.